

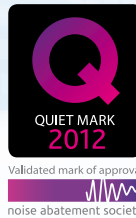

BATHROOM EXTRACT FANS

SILENT-100 DESIGN 3C Series



Range of axial extractors with airflow rates of approx. 85 m³/h, for connection to 100 mm diameter circular ducting.

Motor mounted on silent-elastic-blocks which absorb the vibrations and allow offering very low noise level. All the fans are manufactured from injection moulded plastic, fitted with automatic shutter and single phase 230V-50Hz, class B low consumption motor equipped with thermal overload protection. All the fans are class II insulation, IP45 rated and suitable to operate with air temperature up to 40°C.



SILVER version

SILENT-100 CZ DESIGN 4C: Different colours available.

40C models incorporate 5 interchangeable bars colours (white, clear, blue, green, red and yellow).



Lp
**26,5
dB**

IP45

consumption
8W!

Back draft shutter



To prevent air entry and limit heat leakage when the extractor is not operating. It opens due to the pressure of the air

Silent-blocks



Motor mounted on "Silent-elastic-block" to prevent vibration and noise transmission

Quiet operation

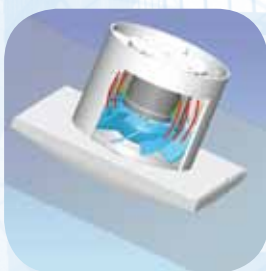

SILENT-100 Design

In usual extract fans the vibrations are transmitted to the surrounding areas while in SILENT extractor fans the vibrations are absorbed by the Silent Blocks



Usual extractor

Models 3C



Interchangeable bars colours let the fan blend in with every setting. 4 colours to match the decor of the room: blue, red, green and yellow

Models features

	CZ DESIGN 3C	CRZ DESIGN 3C	CHZ DESIGN 3C	CZ SILVER DESIGN 3C	CRZ SILVER DESIGN 3C	CHZ SILVER DESIGN 3C
Pilot light	•	•	•	•	•	•
Backdraft shutter	•	•	•	•	•	•
Adjustable Run-On-Timer (1-30min)		•	•		•	•
Adjustable humidistat			•			•
Ball bearings	•	•	•	•	•	•
Silver colour				•	•	•
kit bar lights 4 colours	•	•	•	•	•	•

Technical characteristics

Model	Abs. power at free discharge (W)	Voltage (V) 50 Hz	Sound pressure level* (dB(A))	Airflow at free discharge (m ³ /h)	Insulation/ IP	Ø duct (mm)	Weight (kg)
SILENT-100 DESIGN 3C	8	230	26,5	85	II / IP45	100	0,65
KIT SILENT-100 DESIGN 12V** 3C	12	12	26,5	80	III / IP57	100	0,65

* Sound pressure level measured at 3 m at free air conditions.

** Delivered with CT-12/14 transformer.

Dimensions (mm)

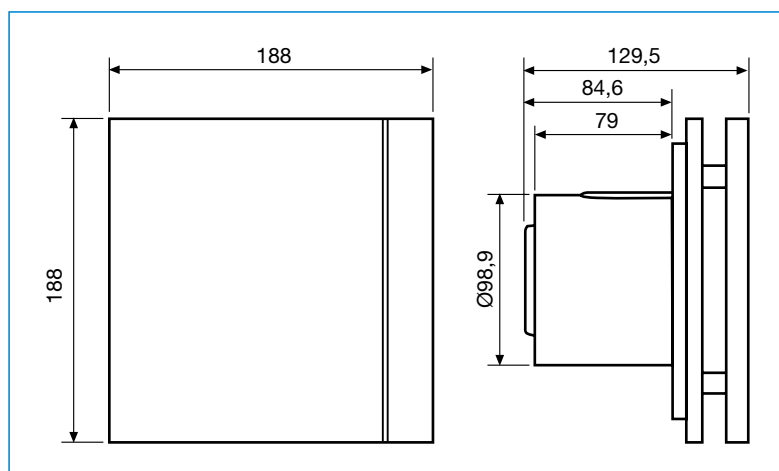

Performance curve

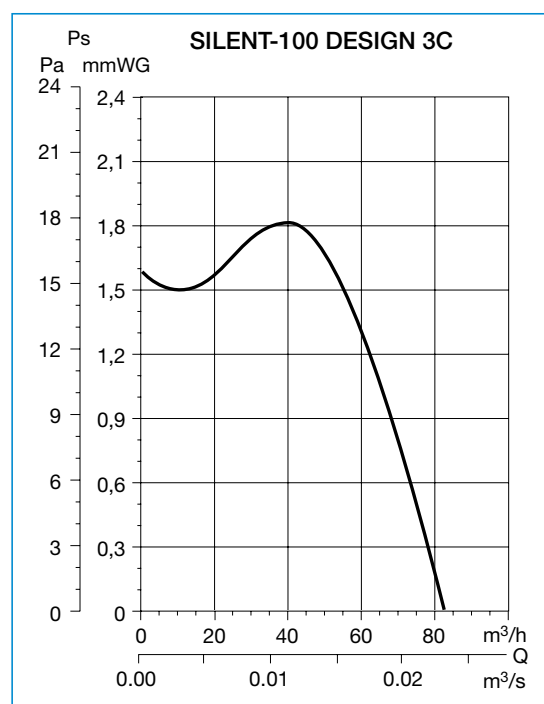

Accessories



GSA-100
Flexible aluminium ducting



GRA-70
Aluminium exterior grille



WALL KIT
Fixed shutter and telescopic duct (200 to 420 m)



CX-80/125
Worm drive ducting clip



PER-100W
Back draft shutter



WINDOW KIT



BATHROOM EXTRACT FANS

SILENT-100 DESIGN

ECOWATT Series



Validated mark of approval
noise abatement society

Range of axial extractors with airflow rates of approx. 85 m³/h, high-performance, low-consumption Brushless motors, for connection to 100 mm diameter circular ducting.

Motor mounted on **silent-elastic-blocks** which absorb the vibrations and allow offering very low noise level. All the fans are manufactured from injection moulded plastic, fitted with automatic shutter and single phase 230V-50/60Hz, low consumption motor equipped with thermal overload protection. All the fans are class II insulation, IP45 rated and suitable to operate with air temperature up to 40°C.

With **consumption of only 5W**, the SILENT ECOWATT series extractors are especially recommended toilets, bathrooms and installations **where the extractor will require long working hours** resulting in a considerable reduction in energy costs.

ENERGY EFFICIENT



VENTILATION SYSTEM

Lp
26,5 dB

Low noise!

IP45

Water protected!

consumption
5W!

Energy efficient!

SILENT-100 DESIGN ECOWATT

Bathroom and toilet extract fans

Back draft shutter



To prevent air entry and limit heat leakage when the extractor is not operating. It opens due to the pressure of the air

Silent-blocks



Motor mounted on **"Silent-elastic-block"** to prevent vibration and noise transmission

Quiet operation

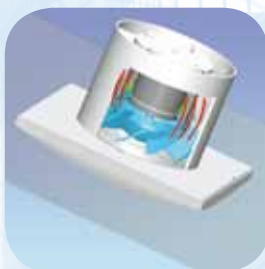

SILENT-100 ECOWATT DESIGN Usual extractor

In usual extract fans the vibrations are transmitted to the surrounding areas while in SILENT extractor fans the vibrations are absorbed by the Silent Blocks

Models 3C



Interchangeable bars colours let the fan blend in with every setting. 4 colours to match the decor of the room: blue, red, green and yellow

Models features

	CZ	GRZ	CHZ	CZ SILVER	CRZ SILVER	CHZ SILVER
DC motor	•	•	•	•	•	•
Pilot light	•	•	•	•	•	•
Backdraft shutter	•	•	•	•	•	•
Adjustable Run-On-Timer		•	•		•	•
Adjustable humidistat			•			•
Silver colour				•	•	•

Technical characteristics

Model	Speed (r.p.m.)	Abs. power at free discharge (W)	Voltage (V) 50 Hz	Sound pressure level* (dB(A))	Airflow at free discharge (m³/h)	Insulation/ IP	Ø duct (mm)	Weight (Kg)
SILENT-100 DESIGN ECOWATT	2100	5	230	26,5	85	II / IP45	100	0,65

* Sound pressure level measured at 3 m at free air conditions.

Performance curve

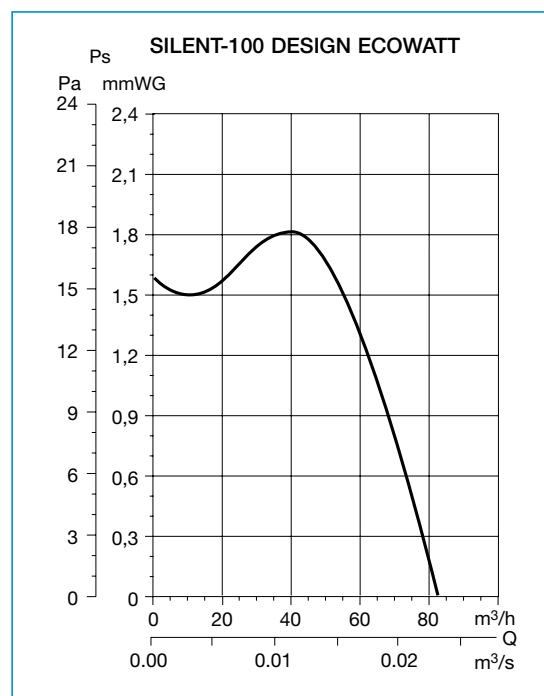

Dimensions (mm)

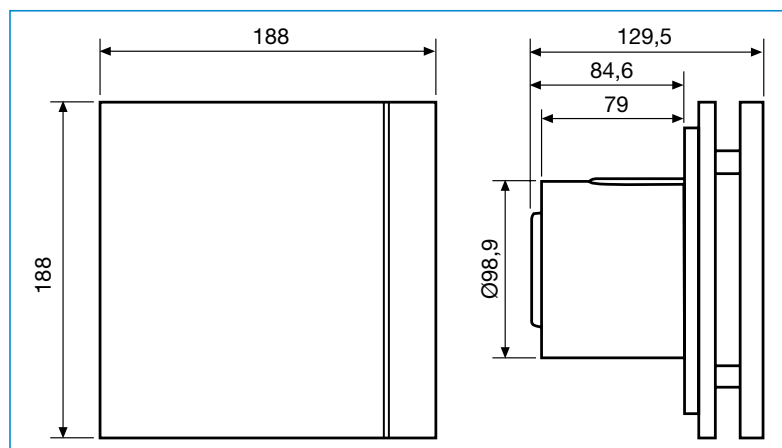

Accessories



GSA-100
Flexible aluminium ducting



GRA-70
Aluminium exterior grille



Fixed shutter and telescopic duct (200 to 420 m)



CX-80/125
Worm drive ducting clip



PER-100W
Back draft shutter



WINDOW KIT



BATHROOM EXTRACT FANS

SILENT-200 DESIGN 3C Series



Range of axial extractors with airflow rates of approx. 175 m³/h, for connection to 120 mm diameter circular ducting.

Motor mounted on silent-elastic-blocks which absorb the vibrations and allow offering very low noise level. All the fans are manufactured from injection moulded plastic, fitted with automatic shutter and single phase 230V-50Hz, class B low consumption motor equipped with thermal overload protection. All the fans are class II insulation, **IP45** rated and suitable to operate with air temperature up to 40°C.

Lp
35
dB

IP45

consumption
16W!



Different styles with the bars colours.

SILVER versions can be supplied with an aesthetical silver front grille.

Back draft shutter



To prevent air entry and limit heat leakage when the extractor is not operating. It opens due to the pressure of the air

Silent-blocks



Motor mounted on "Silent-elastic-block" to prevent vibration and noise transmission

Quiet operation

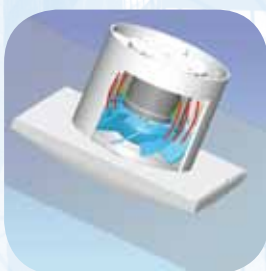

SILENT-200 DESIGN-3C

In usual extract fans the vibrations are transmitted to the surrounding areas while in SILENT extractor fans the vibrations are absorbed by the Silent Blocks



Usual extractor

Models 3C



Interchangeable bar lights let the fan blend in with every setting. 4 colours to match the decor of the room: blue, red, green and yellow

Models features

	CZ DESIGN 3C	CRZ DESIGN 3C	CHZ DESIGN 3C	CZ SILVER DESIGN 3C	CRZ SILVER DESIGN 3C	CHZ SILVER DESIGN 3C
Pilot light	•	•	•	•	•	•
Backdraft shutter	•	•	•	•	•	•
Adjustable Run-On-Timer (1-30min)		•	•		•	•
Adjustable humidistat			•			•
Ball bearings	•	•	•	•	•	•
Silver colour				•	•	•
kit bars 4 colours	•	•	•	•	•	•

Technical characteristics

Model	Abs. power at free discharge (W)	Voltage (V) 50 Hz	Sound pressure level* (dB(A))	Airflow at free discharge (m ³ /h)	Insulation / IP	Ø duct (mm)	Weight (kg)
SILENT-200 DESIGN 3C	16	230	35	175	II / IP45	120	0,88

* Sound pressure level measured at 3 m at free air conditions.

Dimensions (mm)

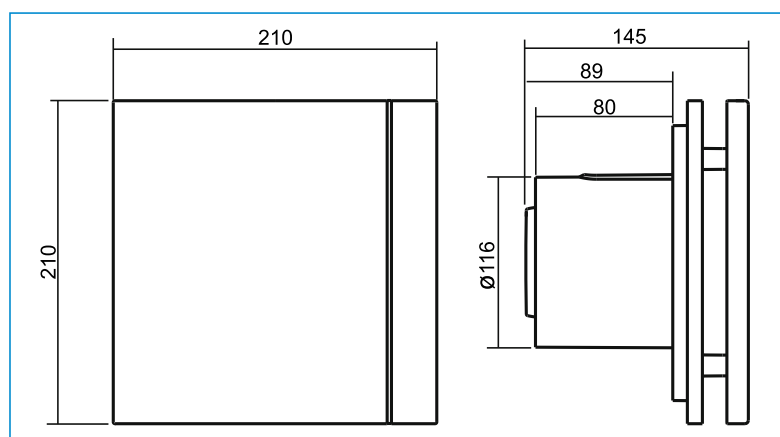

Performance curve

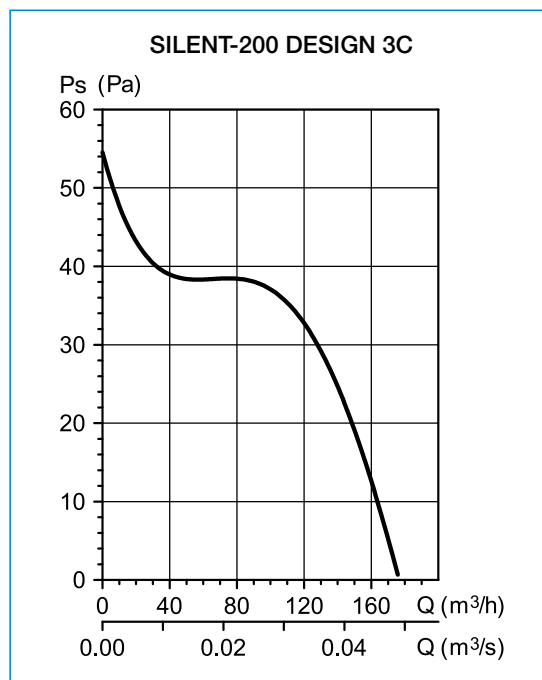

Accessories



GSA-100
Flexible aluminium ducting



GRA-70
Aluminium exterior grille



CX-80/125
Worm drive ducting clip



PER-100W
Back draft shutter