

AXIAL FANS



B5PA

AC WALL MOUNTED AXIAL FANS Plastic Blade

Propellers are manufactured in ideal dimension and got maximum air flow. Designed to be installed directly into walls, ceiling or panels with it's square plate.

Technical Drawings

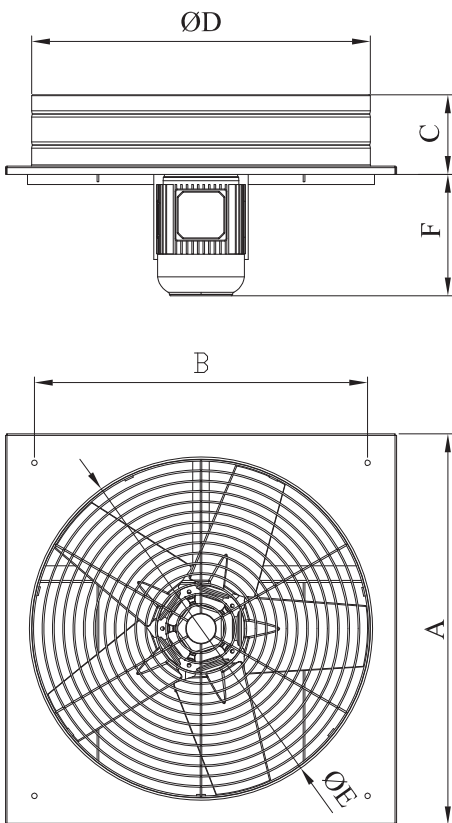

MATERIAL

: The casing is made of electrostatic powder coated sheet metal, impeller is made of plastic.

INSULATION CLASS

: Class B and Class F

DIRECTIVE

: EN 60335-1, EN 60335-2-80

SPEED CONTROL

: Speed can be adjusted using an optional controller.

APPLICATION AREAS

: Factories, stock depots, dye-houses, shopping centers, big halls, etc.

Accessories



BSC-F

TYPE	A	B	C	D	E	F
B5PA 500	600	460	125	510	492	239
B5PA 600	700	550	125	610	592	239
B5PA 700	800	640	170	730	690	259
B5PA 800	950	770	220	830	780	284
B5PA 900	1100	900	250	930	880	336
B5PA 1000	1200	960	250	1030	990	375

Dimensions are in (mm)

TYPE	VOLTAGE	FREQUENCY	POWER	CURRENT	SPEED	AIR FLOW	SOUND PRESSURE LEVEL	WEIGHT
	V	Hz	Kw	(A)	d/d	m ³ /h	dB(A)	kg
B5PAM 500/ B5PAT 500	230/380	50	0.55	3,3/1,5	1400	8500	69	16.6
B5PAM 600/ B5PAT 600	230/380	50	0.75	4,6/2	1400	10500	75	20.5
B5PAM 700/ B5PAT 700	230/380	50	1.1	7,1/2,6	1400	14000	82	33
B5PAM 800/ B5PAT 800	230/380	50	2.2	13,4/5,1	1400	20000	85	52
B5PAT 900	230/380	50	4	8,2	1400	32000	88	61
B5PAT 1000	230/380	50	5.5	11,3	1400	37000	91	90

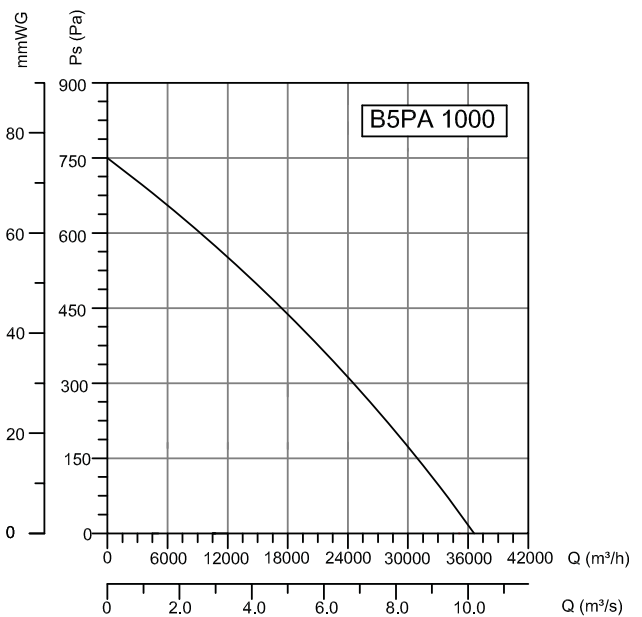
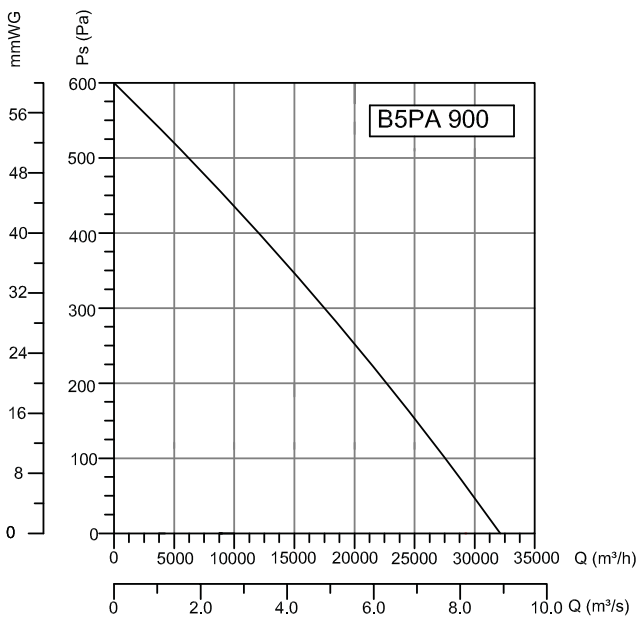
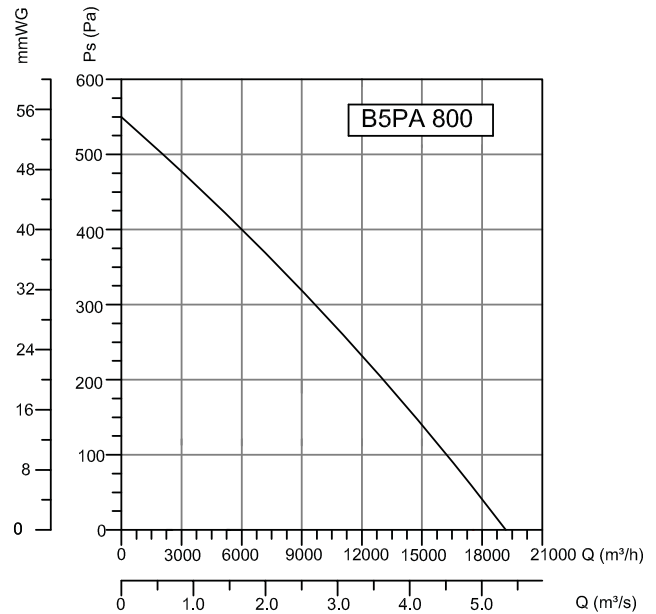
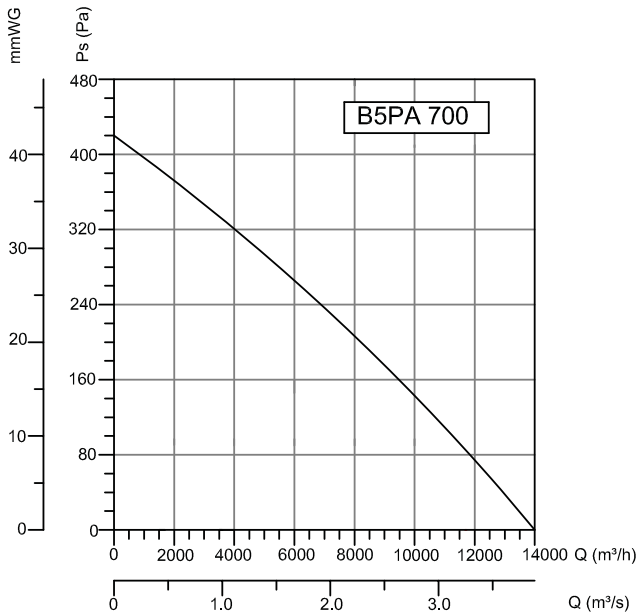
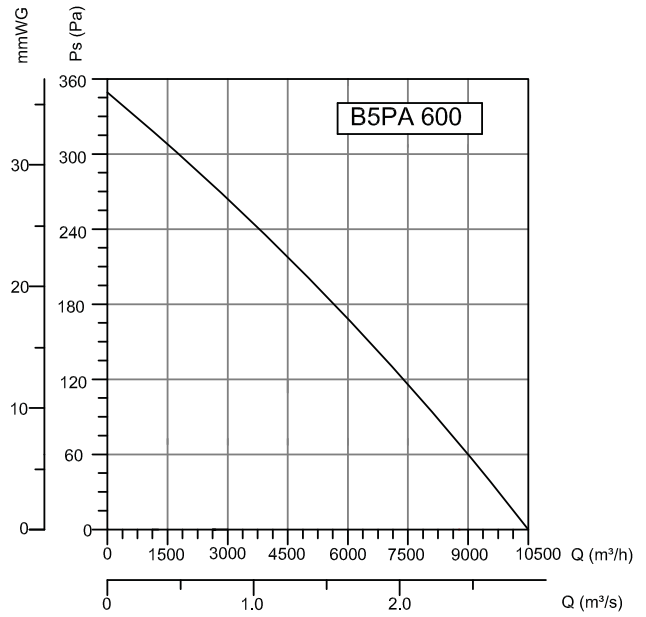
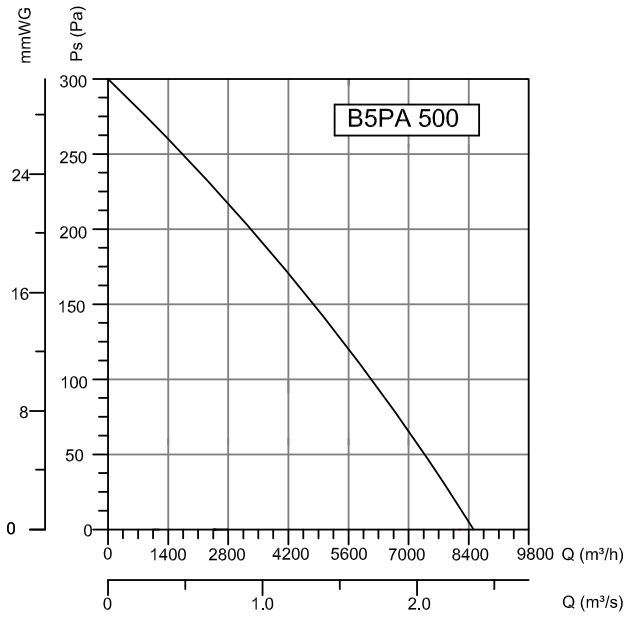

DUCT FANS

ROOF FANS

AXIAL FANS

RADIAL FANS

PLASTIC FANS

VENTILATORS

SMOKE EXHAUST SYSTEMS

ACCESSORIES